

Aromaticity

Coal as a Source of Benzene

1675 - Bituminous coal is distilled to form tars

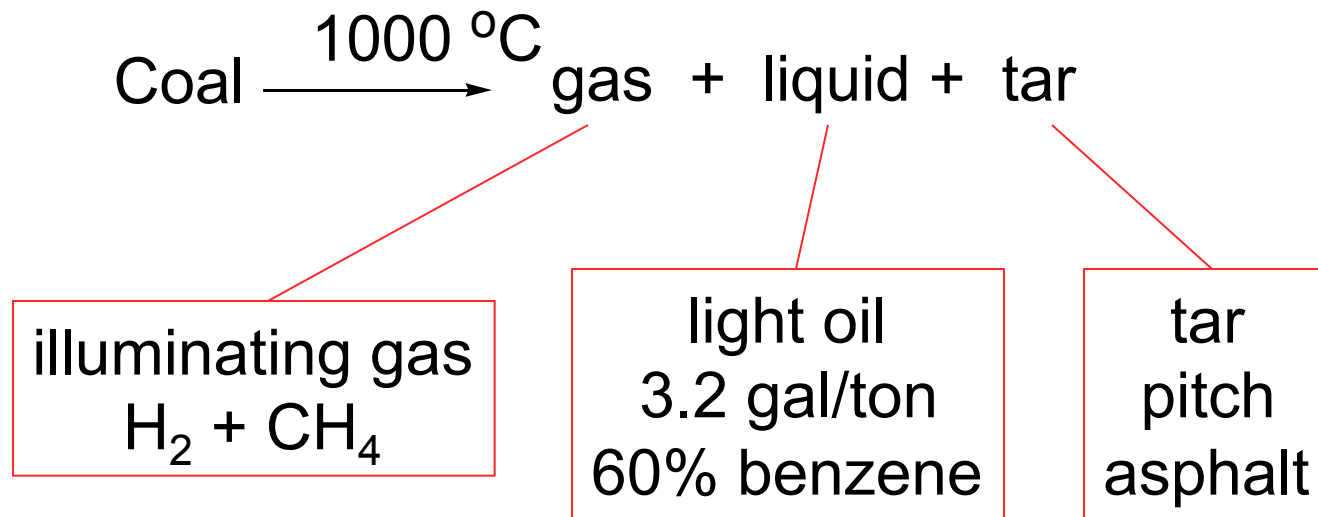

Faraday Isolates Bicarburetted Hydrogen



Michael Faraday
(1791-1867)

1825 - Michael Faraday isolates “bicarburetted hydrogen” ($C_{12}H_6$) from liquid residue in a cylinder of illuminating gas. [C = 6, H = 1]

"One Christmas was so much like another, in those years around the sea-town corner now and out of all sound except the distant speaking of the voices I sometimes hear a moment before sleep, that I can never remember **whether it snowed for six days and six nights when I was twelve or whether it snowed for twelve days and twelve nights when I was six.**"

"A Child's Christmas in Wales" --- Dylan Thomas

The Preparation, Naming and Correct Formula of Benzene



Eilhard Mitscherlich
(1794-1863)

1834 - Mitscherlich prepares benzene (C_6H_6) from benzoic acid by heating with CaO . Benzoic acid was prepared from gum benzoin resin from *Styrax benzoin*.



Kekulé's First Structure of Benzene



August Kekulé
(1829-1896)

1865 - Proposes a cyclic structure for benzene with alternating single and double bonds

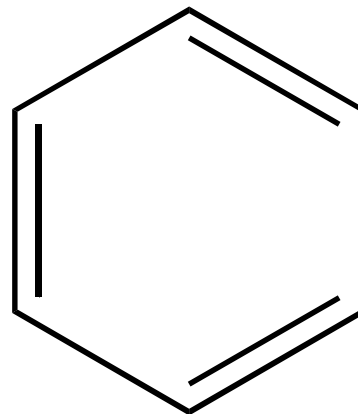

1890- Benzene Fest - [Kekulé's Dream](#)

Ladenburg's Riposte



Albert Ladenburg
(1842 - 1911)

Ladenburg, a former student of Kekulé's, objects to his mentor's formula for benzene because only one o-dibromobenzene is known, not two.

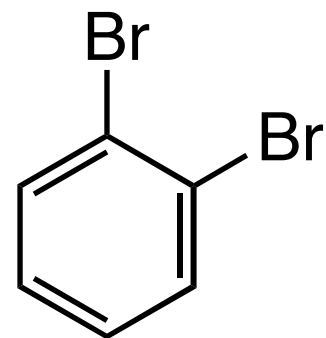
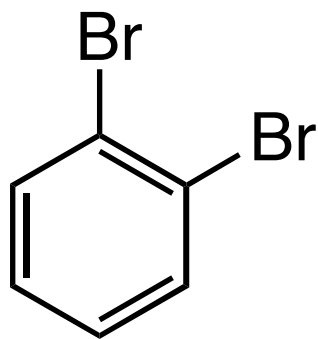

Kekule's Response

1872 - Kekulé revises his theory, suggesting that the single bonds are changing places with the double bonds.

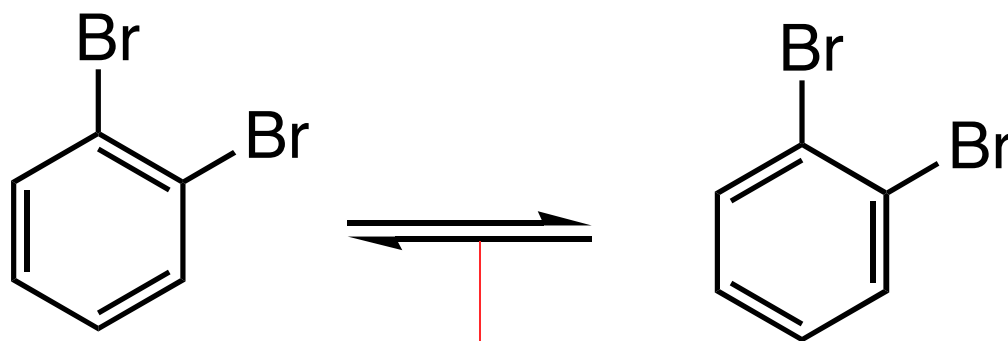

not resonance - barrier implied

Ladenburg's Prismane Structure

1869 - Ladenburg proposes the prismane structure for benzene.

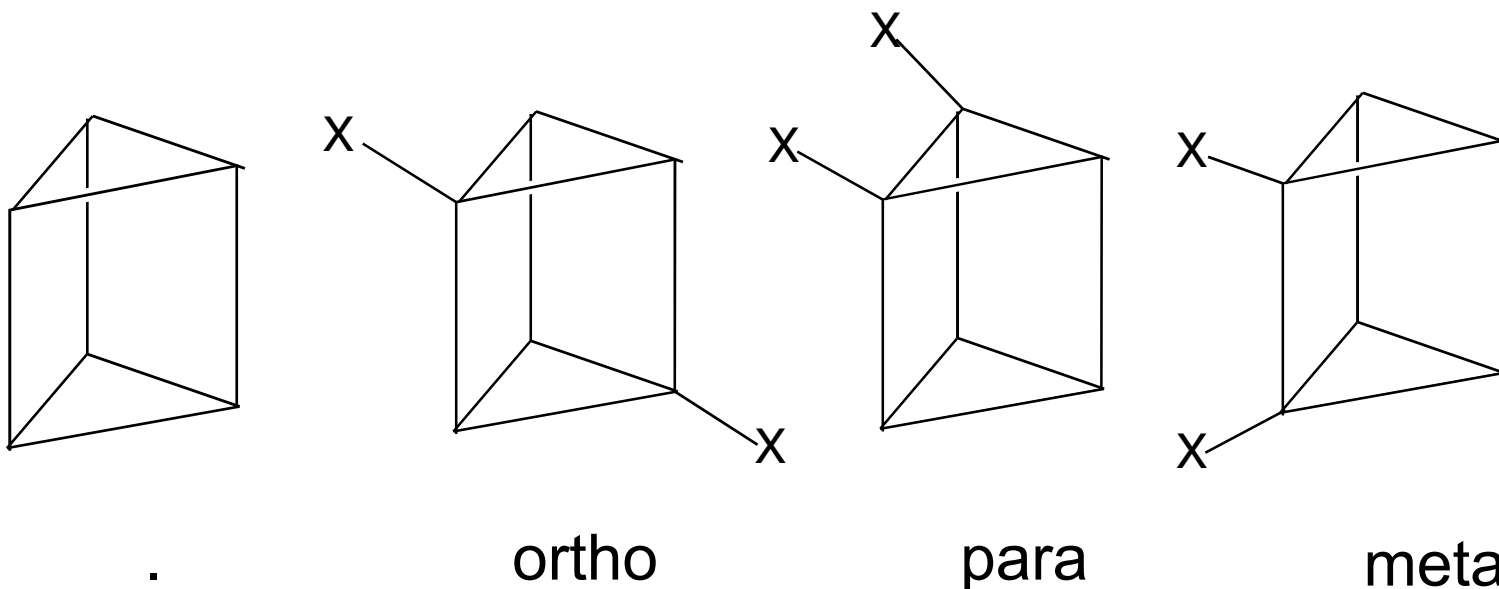

Van 't Hoff's Objection

1869 - Ladenburg proposes the prismane structure for benzene.

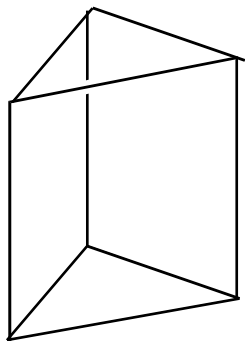

Van 't Hoff objects to Ladenburg's prismane structure because the ortho isomer is chiral and should be resolvable.

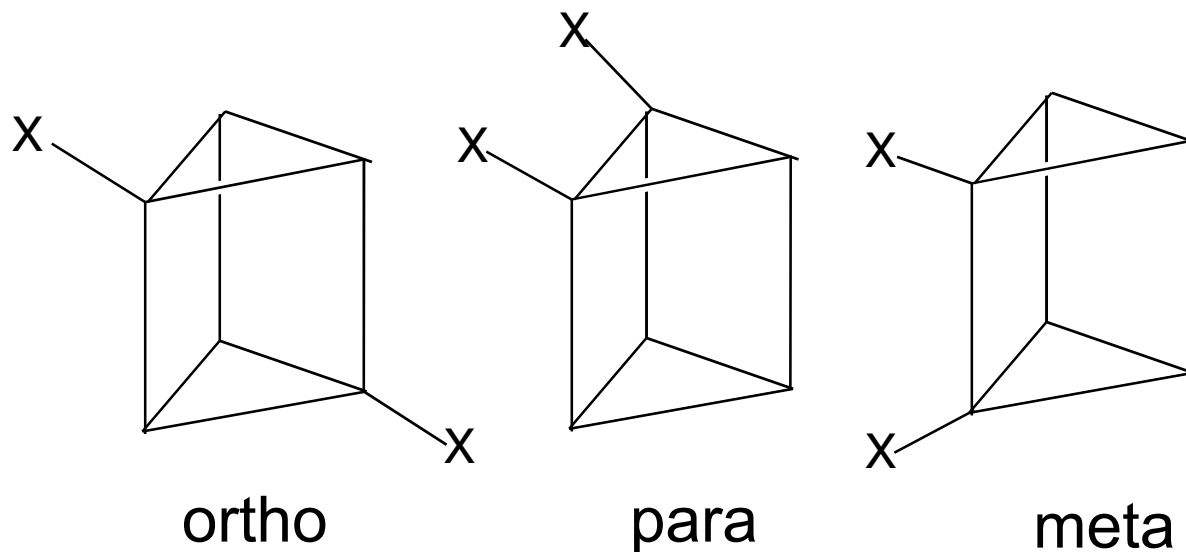

The ortho-Isomer

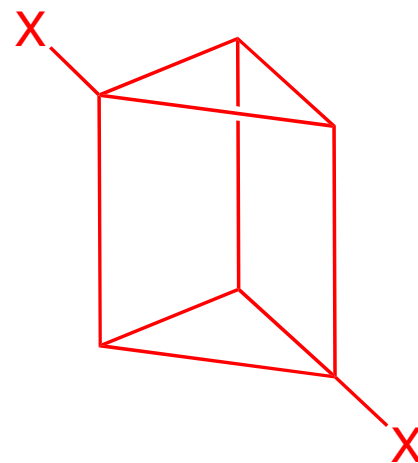
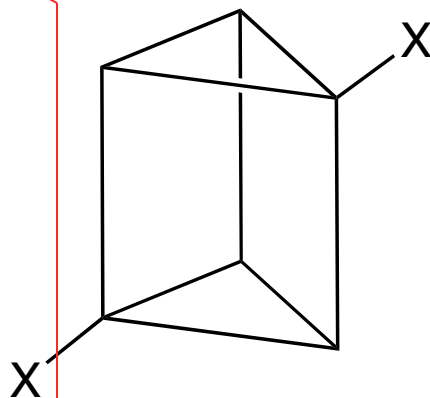
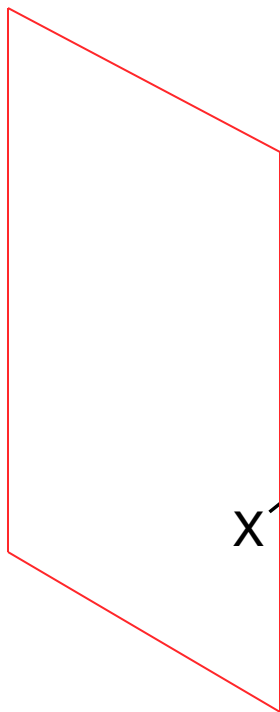
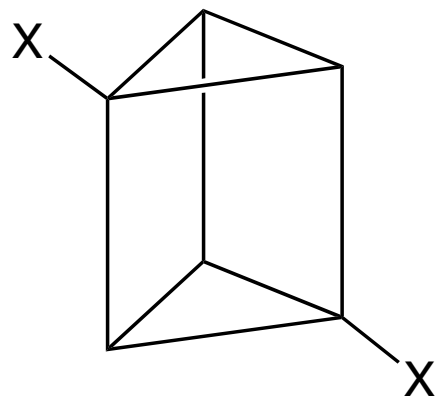
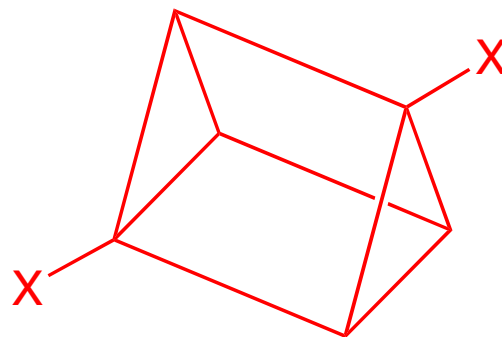
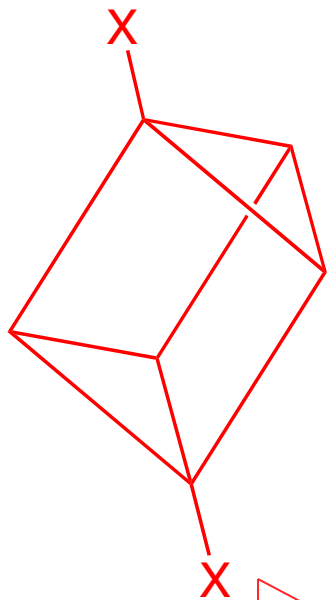

104 Years Later...

1973 - Acton and Katz synthesize prismane.

.

Prismane

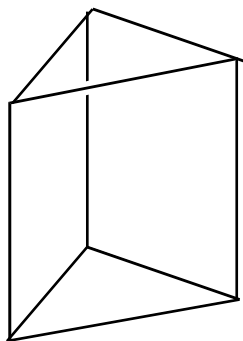

$^1\text{H NMR}$: δ 2.28, s
 $^{13}\text{C NMR}$: 30.6 ppm

Benzene

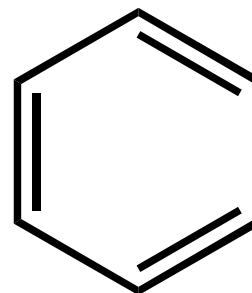

$^1\text{H NMR}$: δ 7.34, s
 $^{13}\text{C NMR}$: 128.4 ppm

Other Benzenes

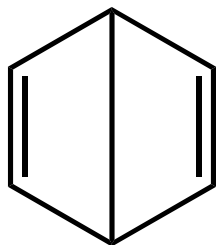

“Dewar benzene”

Dewar (1867)

Stadeler (1868)

Wichelhaus (1869)

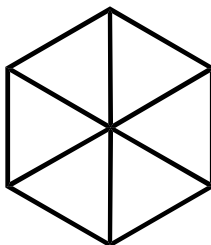

Claus (1867)

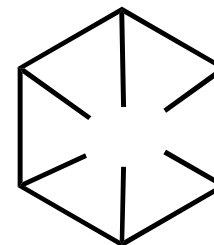
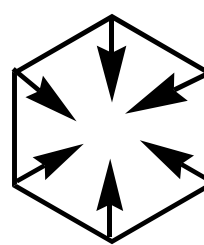

Armstrong-Baeyer (1887)

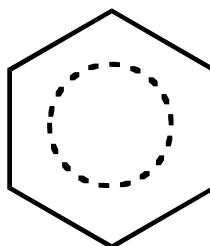

Thiele (1899)

Cyclohexatriene vs. Benzene

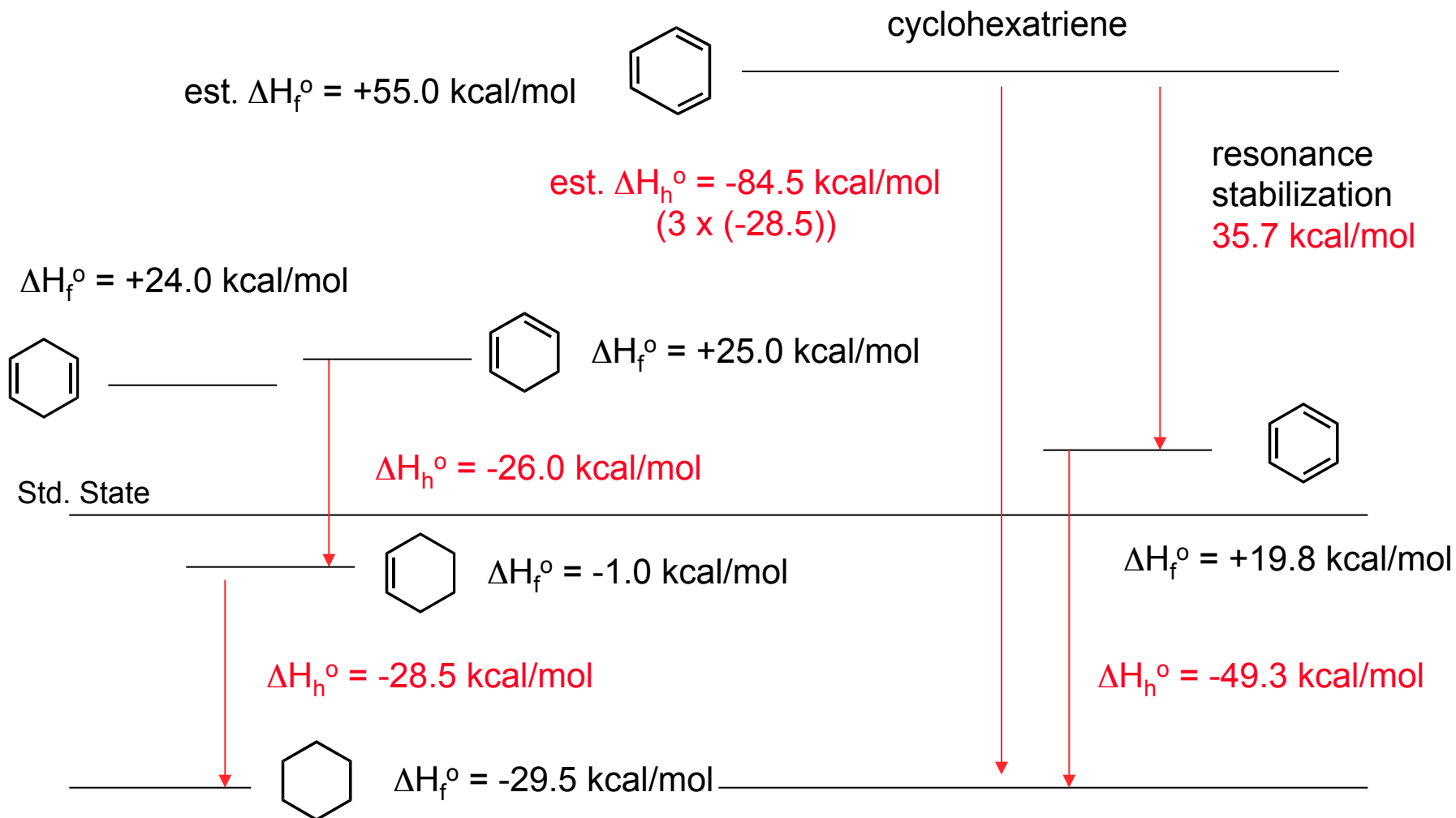

Is Cyclooctatetraene Aromatic?

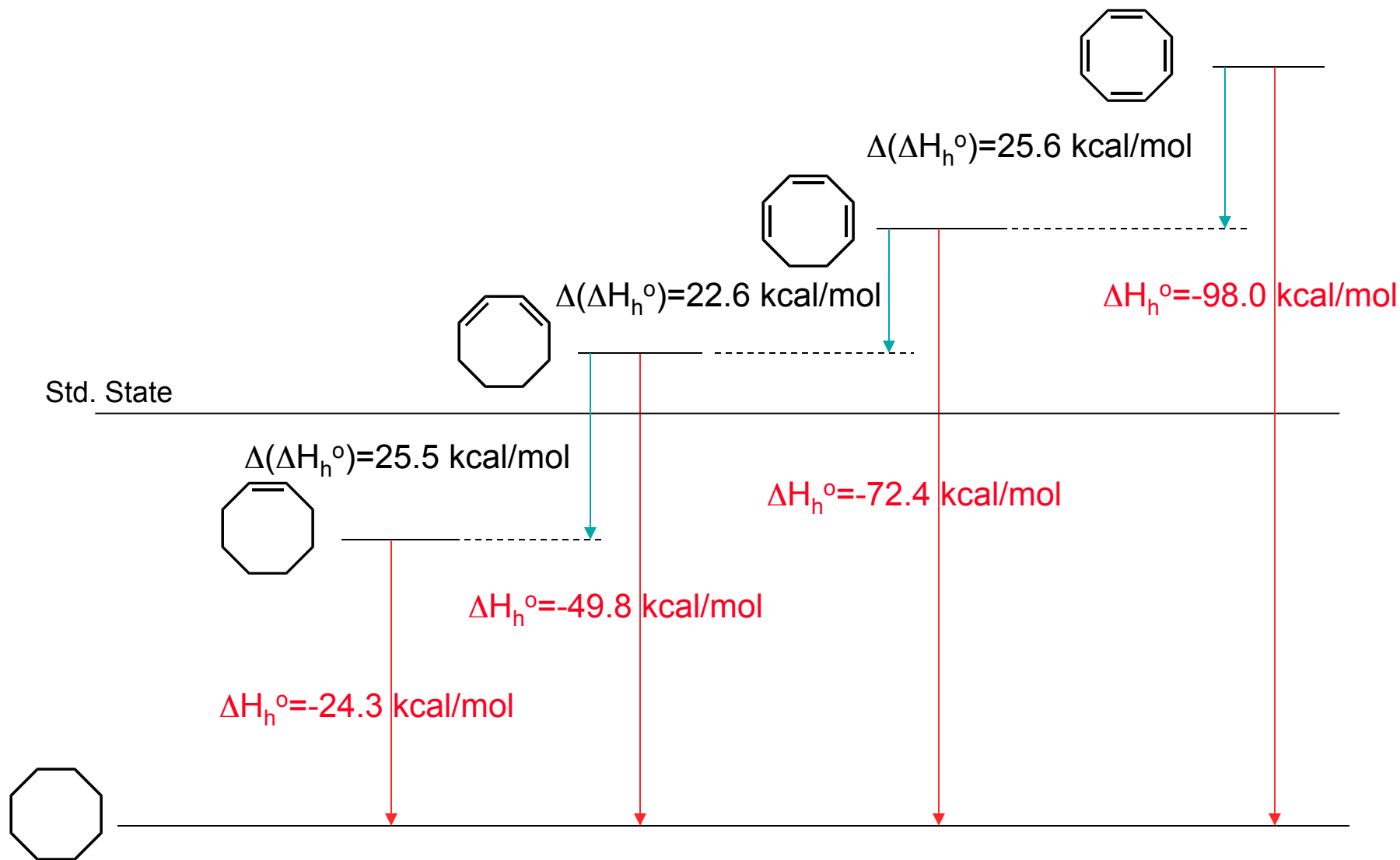

¹H NMR: Aromatic vs. Alkenyl Hydrogens

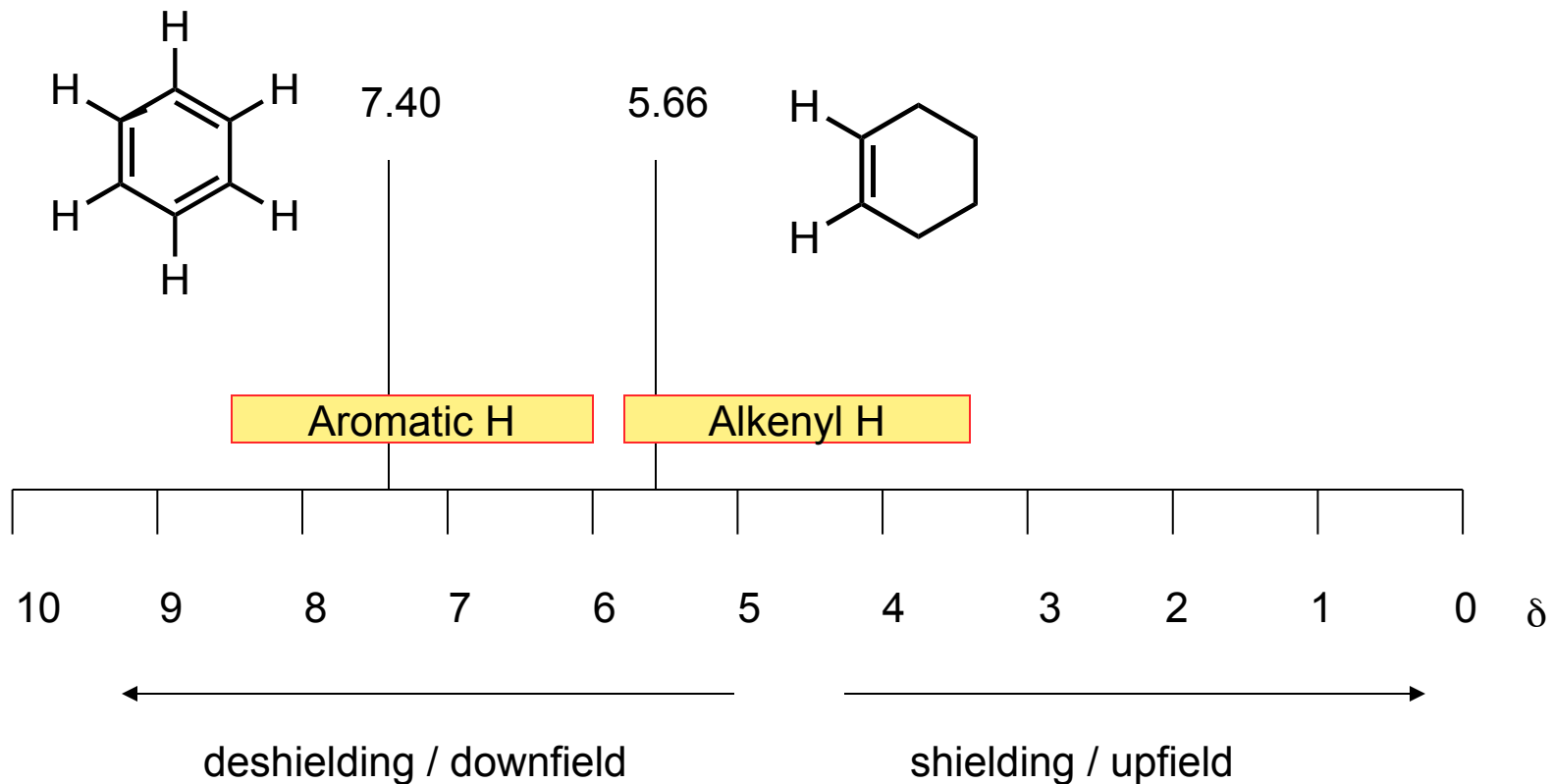

Magnetic Anisotropy

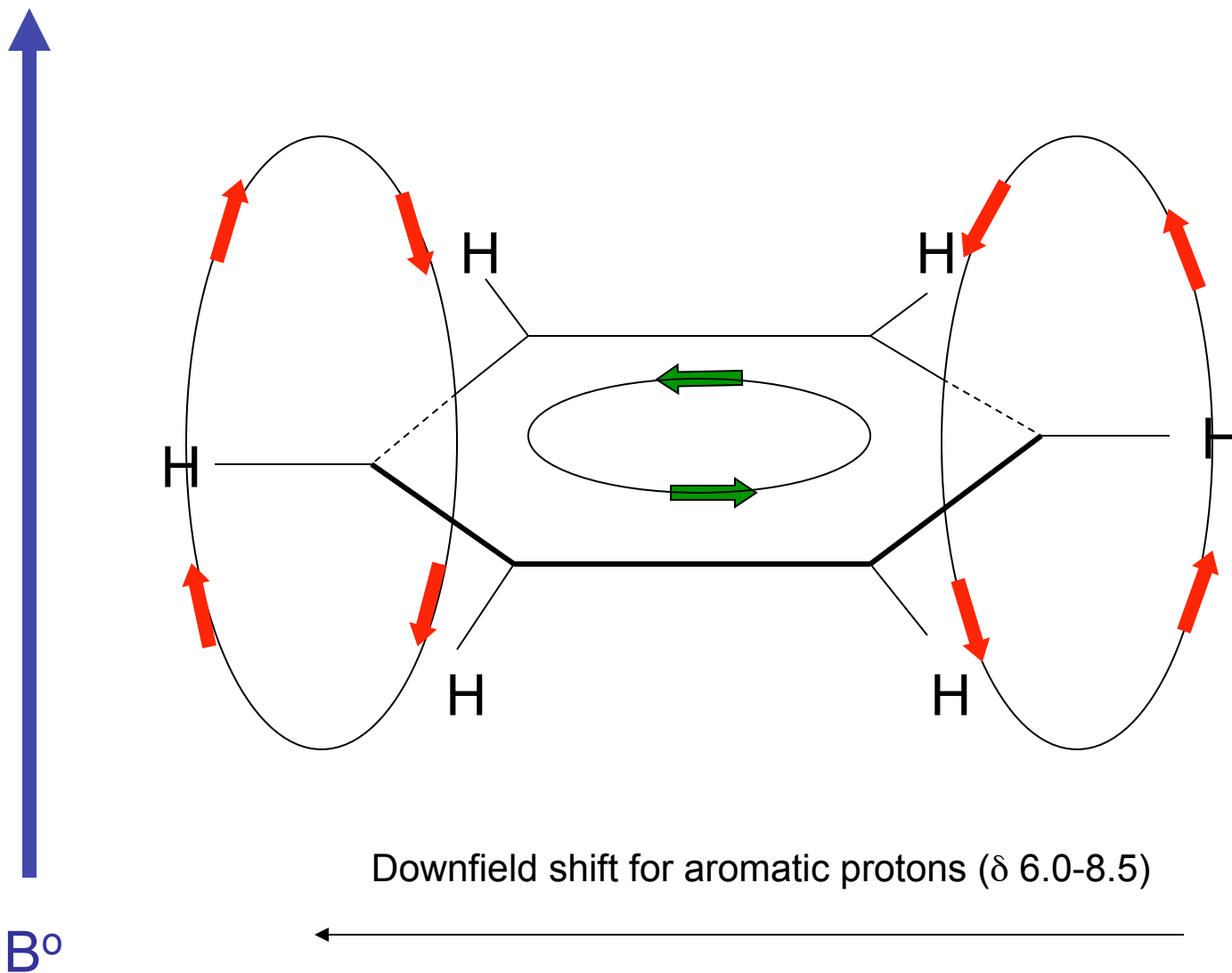

Molecular Orbitals of Benzene

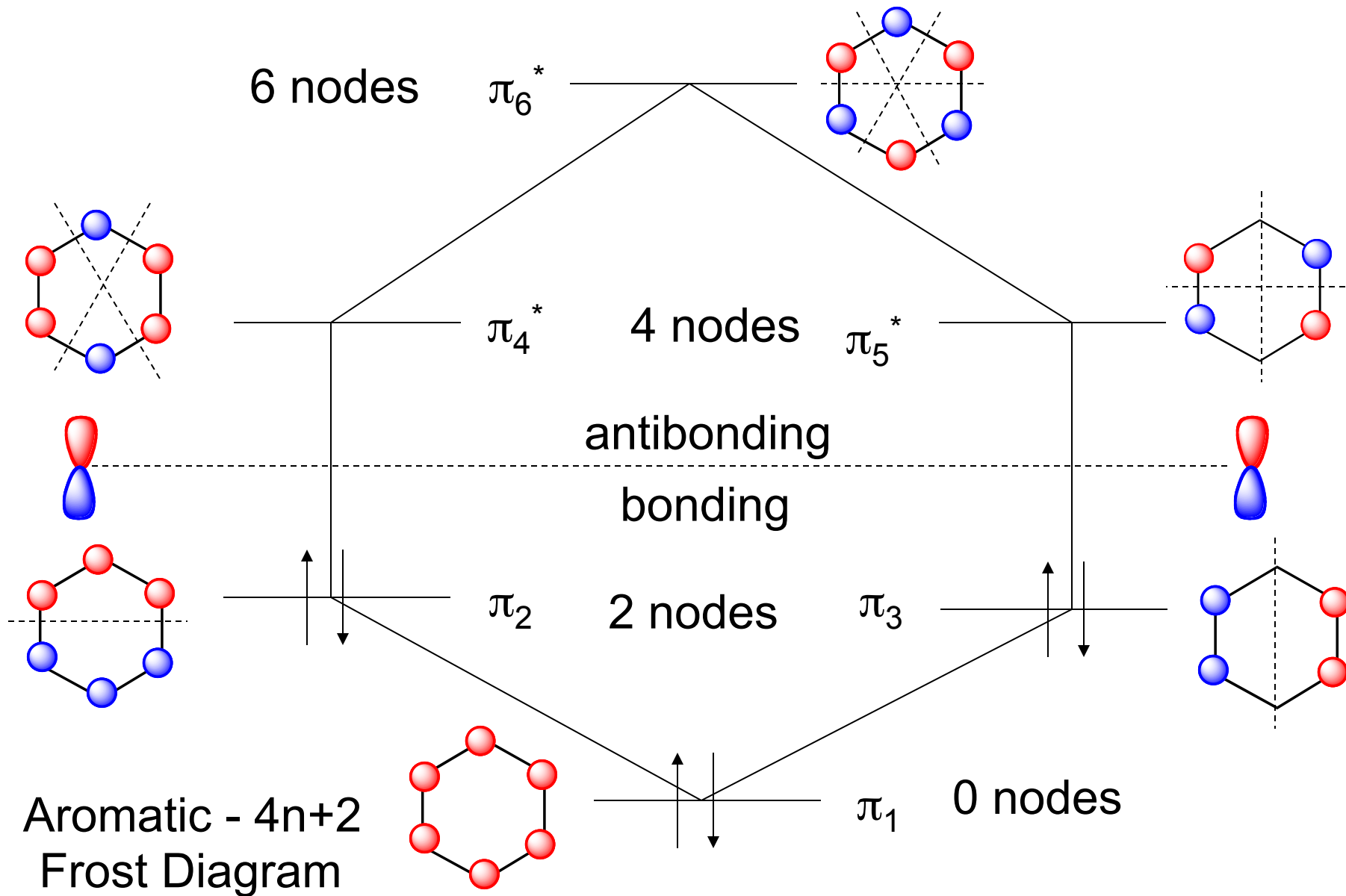

Molecular Orbitals of Cyclooctatetraene

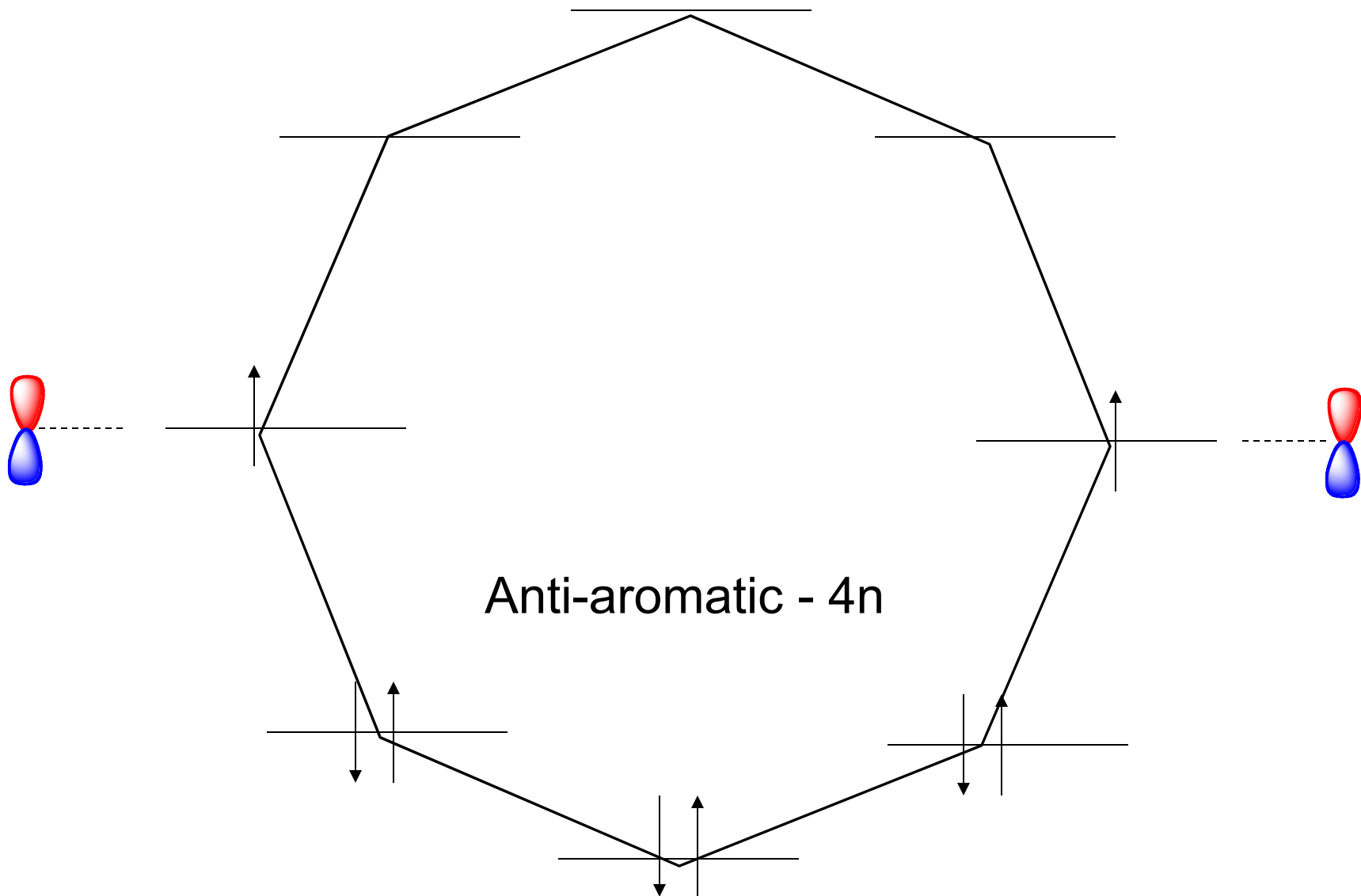

Molecular Orbitals of Cyclooctatetraene Dianion

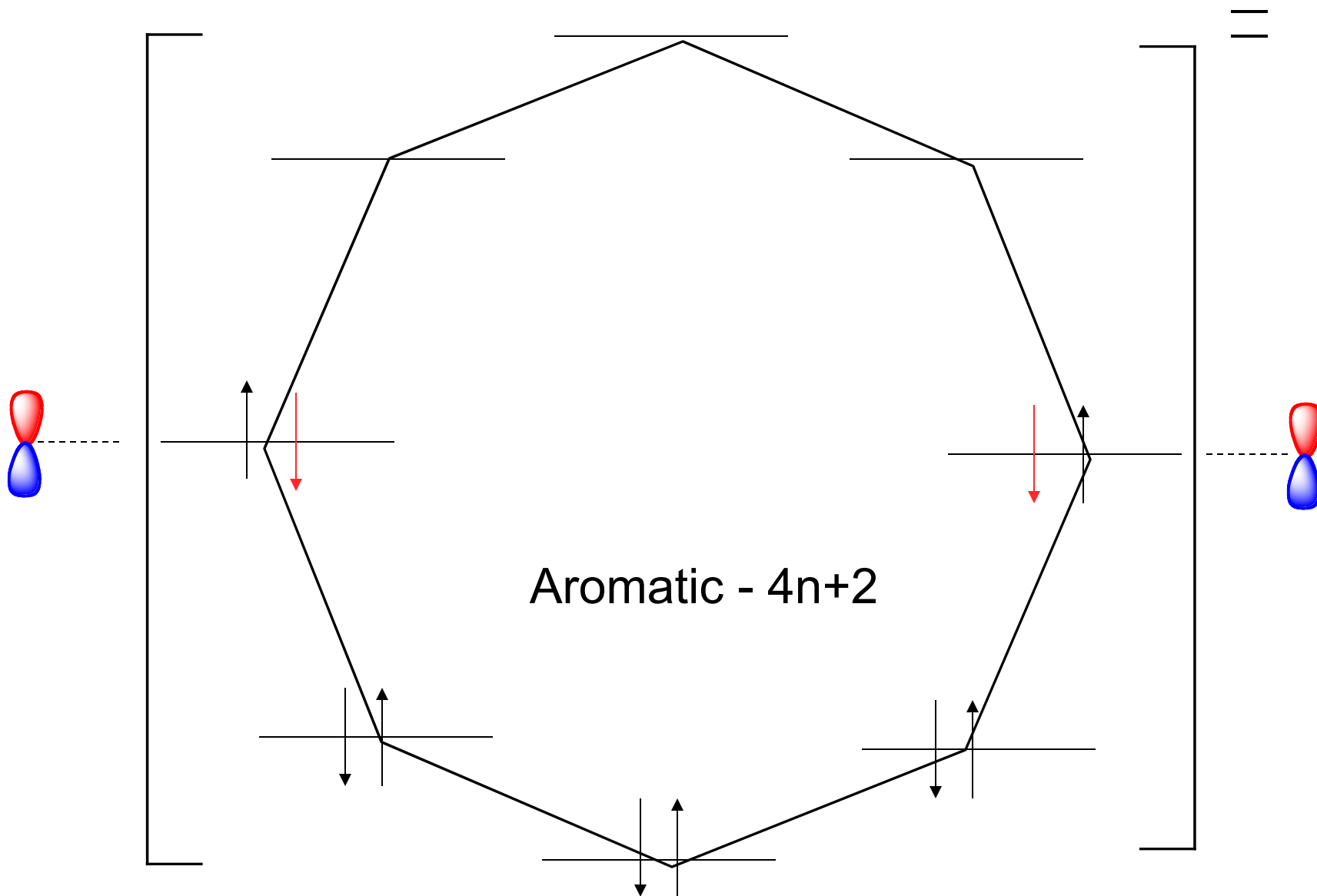

Molecular Orbitals of Cyclobutadiene

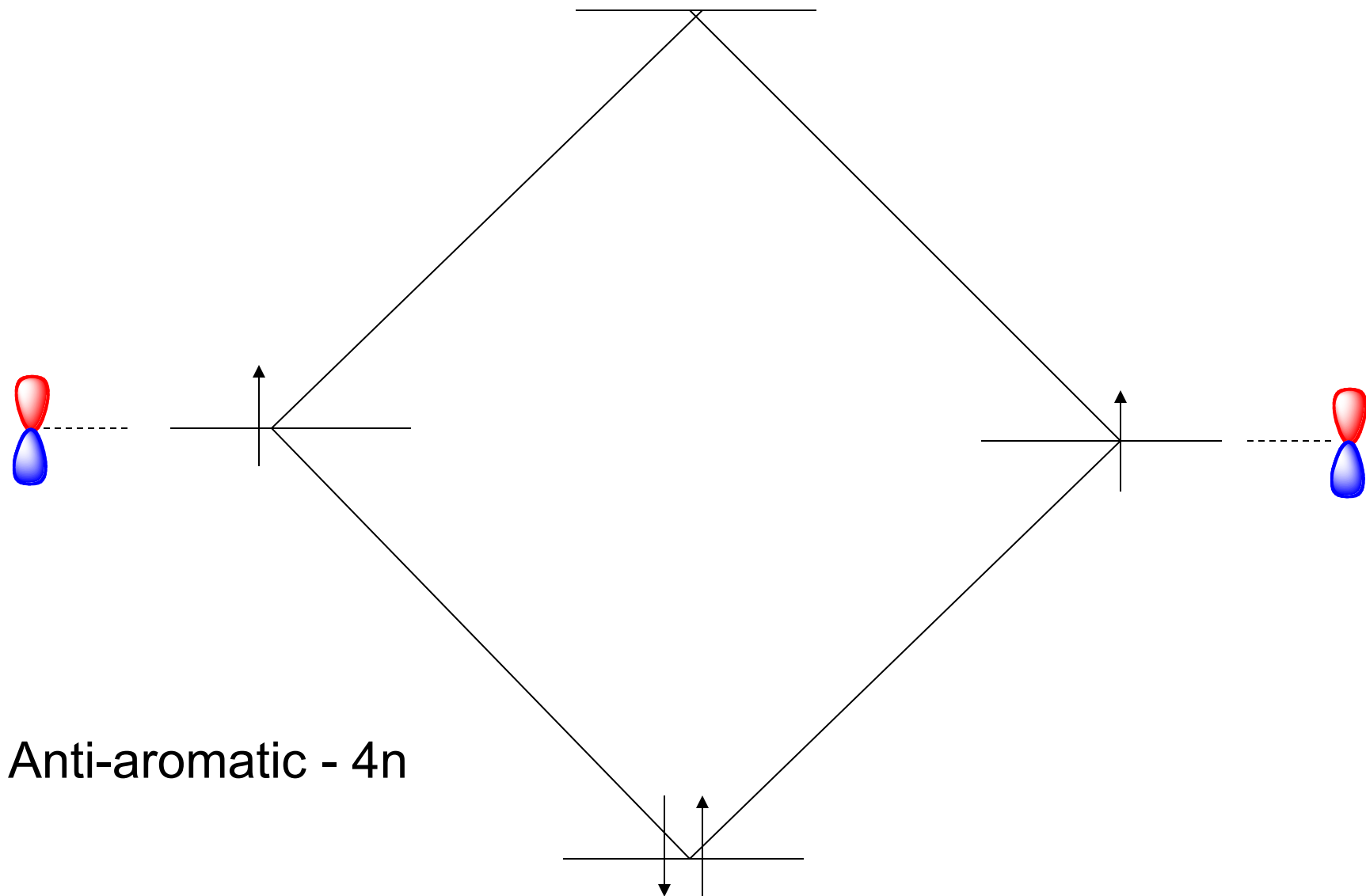

$4n + 2$ (E,Z,Z,E,Z)-Cyclodecapentaene

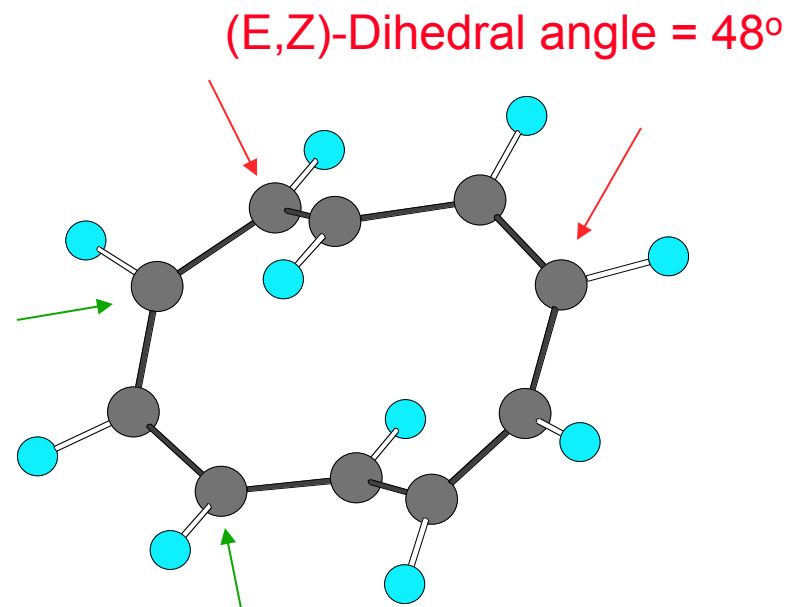
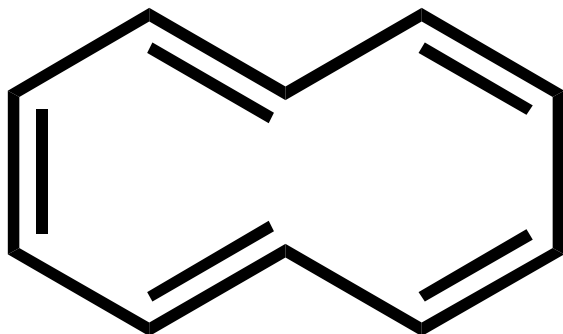

(E,Z)-Dihedral angle = 48°

(Z,Z)-Dihedral angle = 31°

$4n + 2$, non-planar; non-aromatic!

1,6-Methano-(E,Z,Z,E,Z)-Cyclodecapentaene

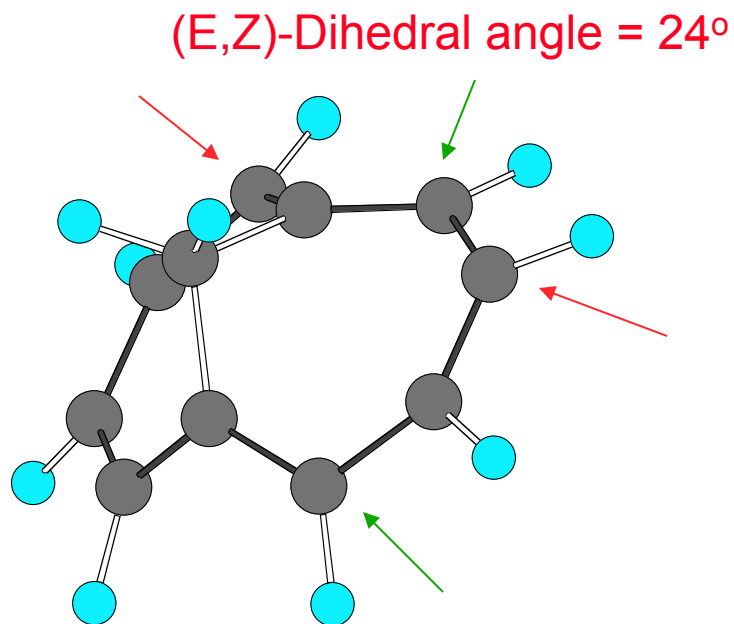
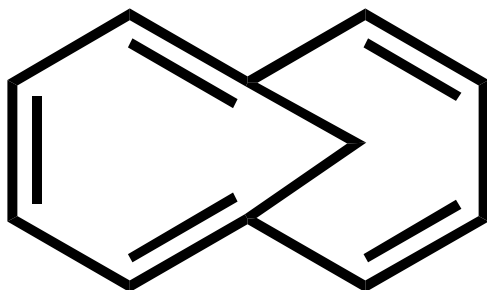

(Z,Z)-Dihedral angle = 0.5°

$4n + 2$, “planar”; aromatic

(E,Z,Z,Z,Z,Z)-Cyclodecapentaene

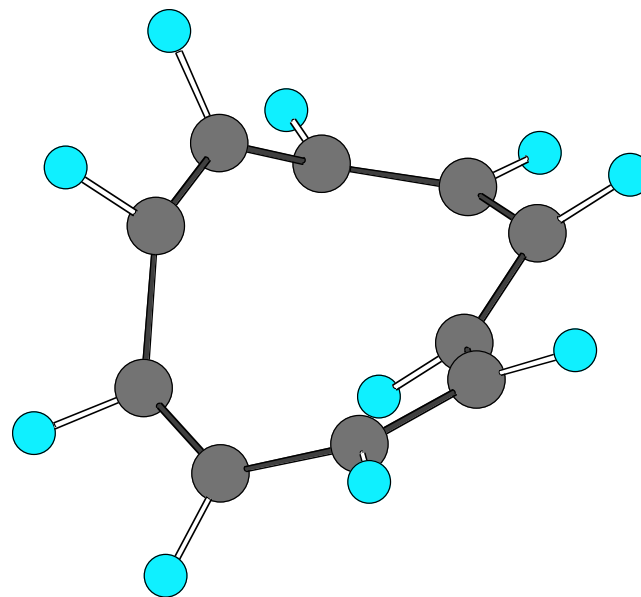
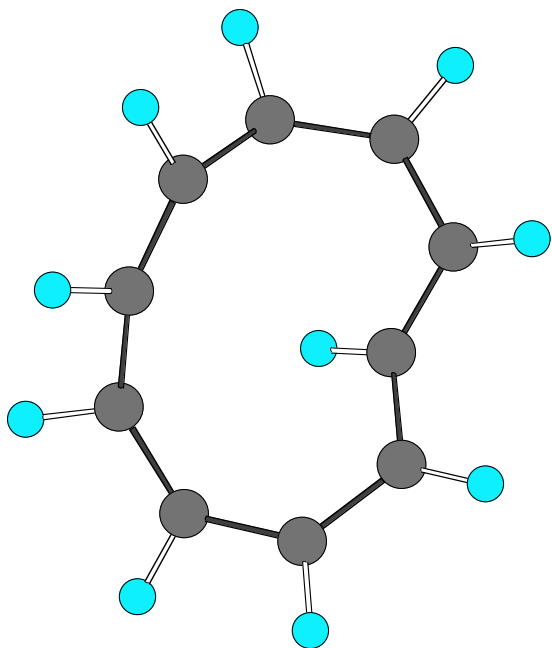

$4n + 2$, non-planar; non-aromatic

Naphthalene and Azulene

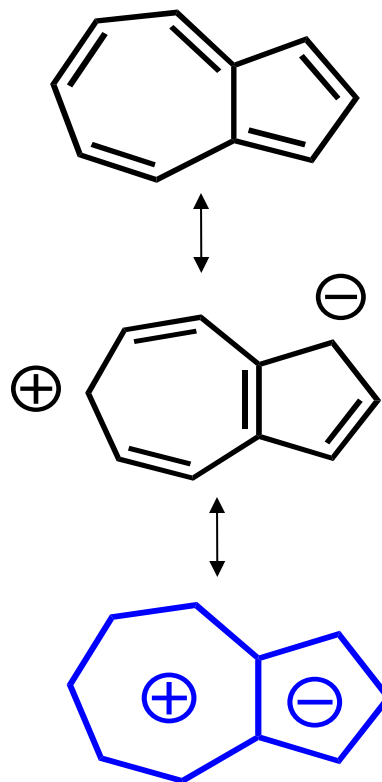
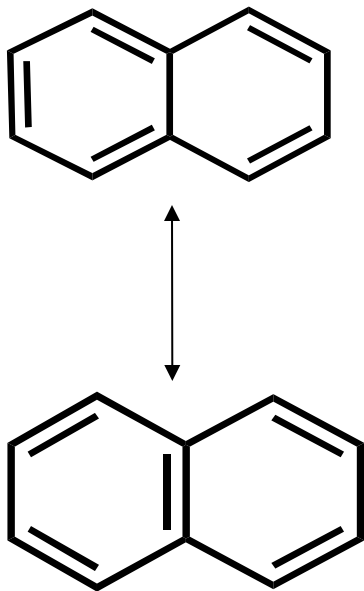

$4n + 2$, planar; aromatic

Pyrenes

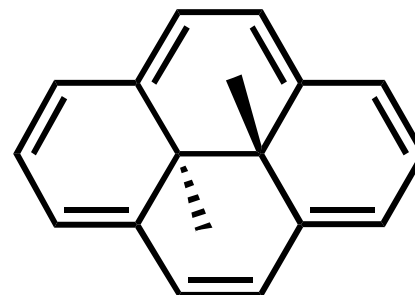
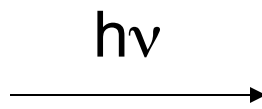
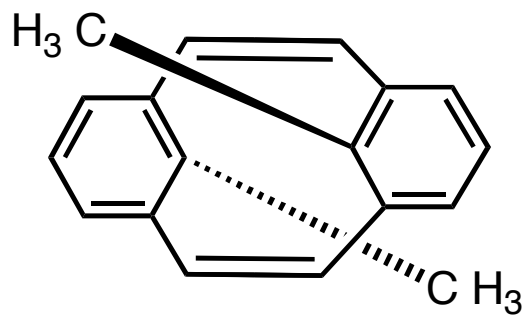

14e: aromatic

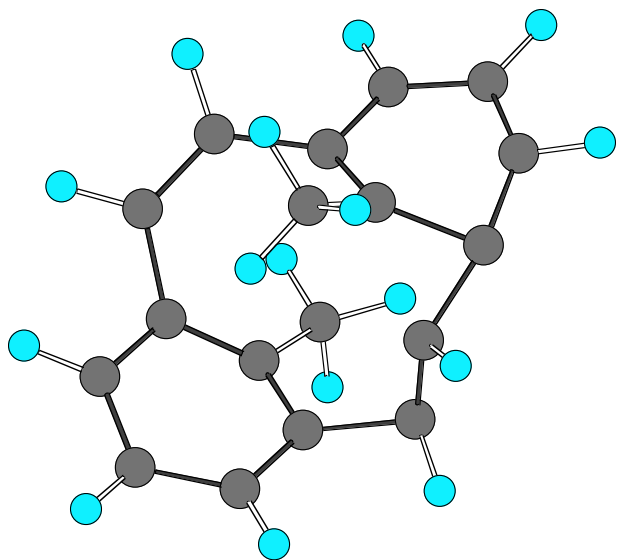

Pyrenes

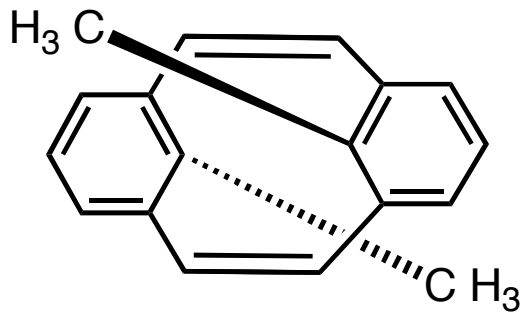

$h\nu$

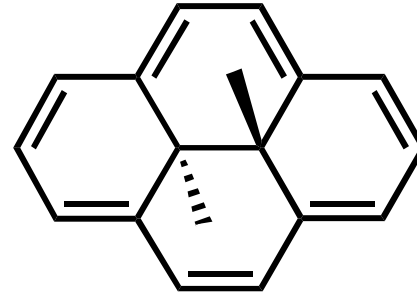

14e: aromatic

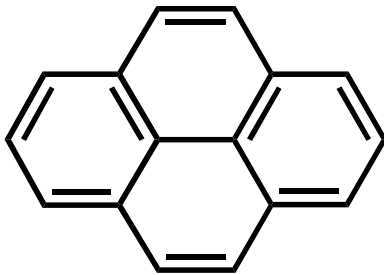

16e: anti-aromatic?

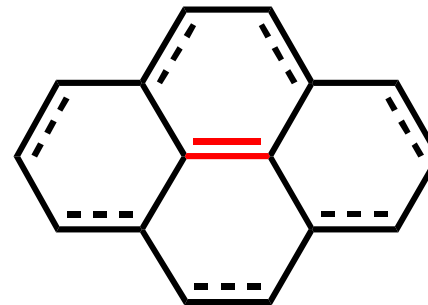
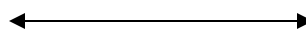

14e: aromatic!

[18]-Annulene

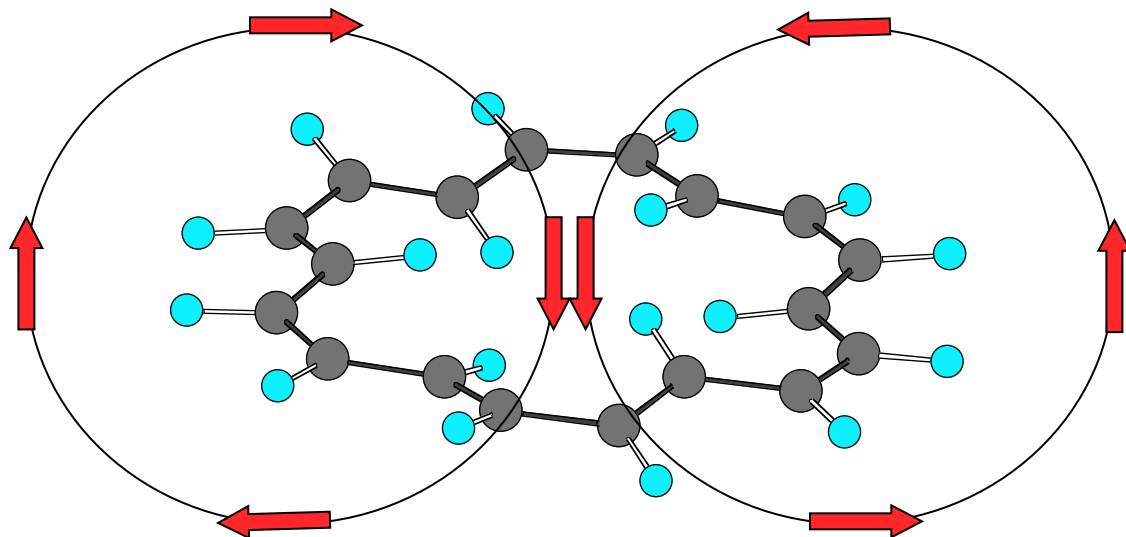
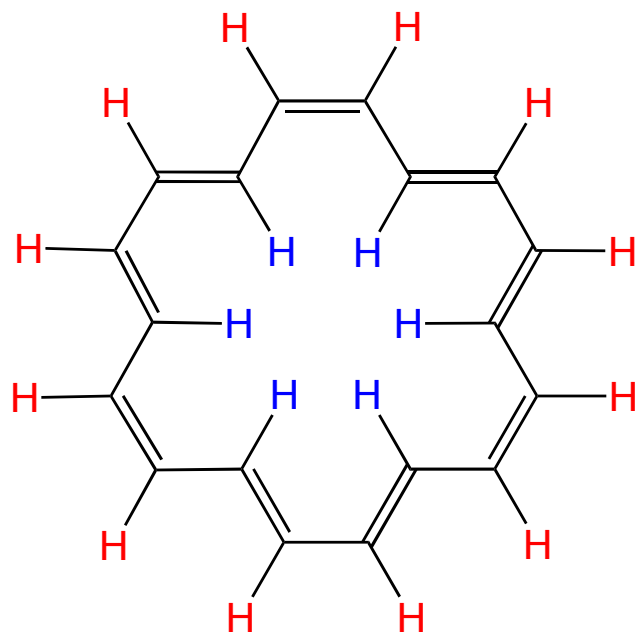

^1H NMR:

120°C ; $\delta 5.45$ (18H,s)

-60°C ; $\delta 9.25$ (12H,s), -2.9 (6H,s)

Aromatic Cations

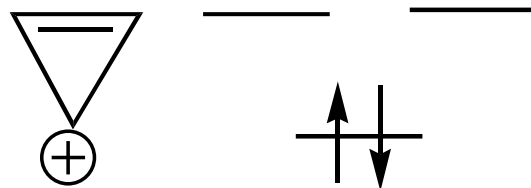

Cyclopropenium cation

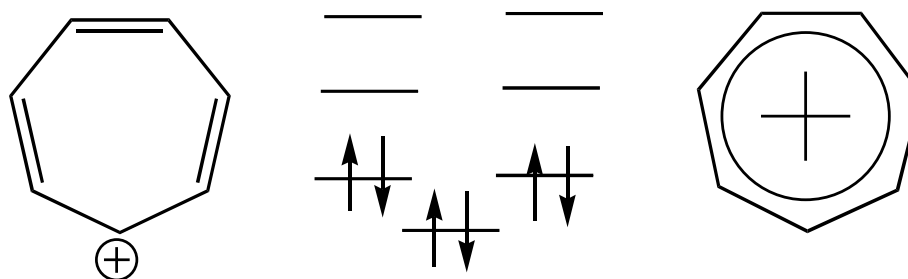

Tropylium cation
 ^1H NMR: $\delta 9.17$, singlet

Aromatic Anions

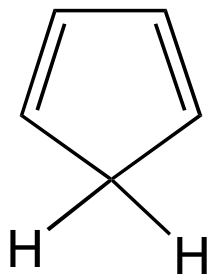

pKa = 16

deprotonation
→

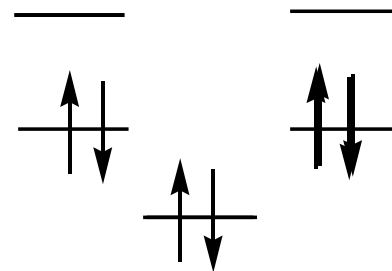
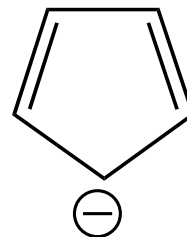

Cyclopentadienyl anion

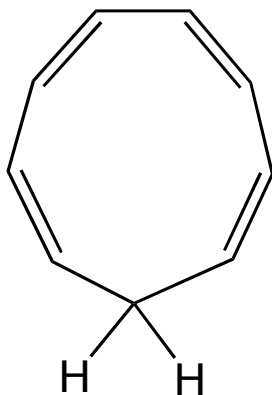

deprotonation
→

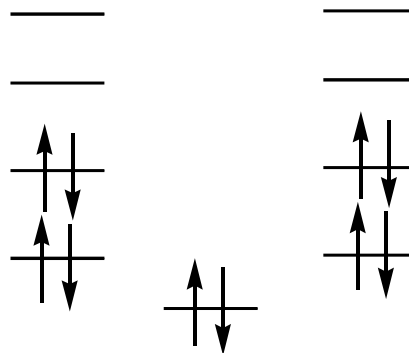
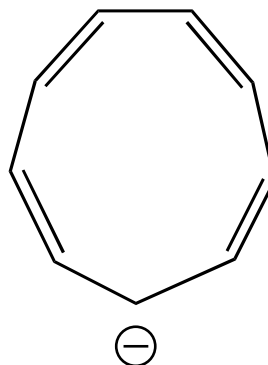

Cyclononatetraenyl anion

Aromatic Dianions I

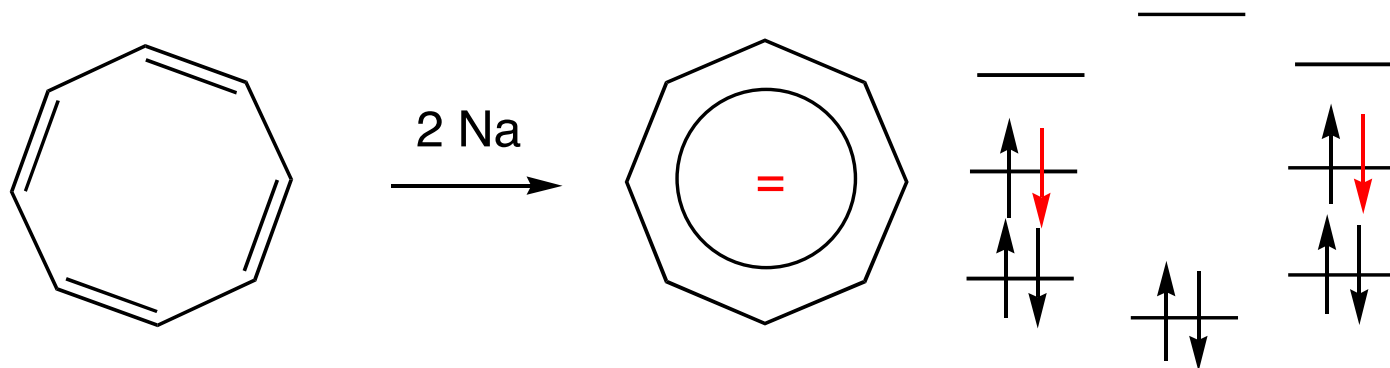

Cyclooctatetraene

anti-aromatic

tub-shaped

^1H NMR: $\delta 6.75$, singlet

Cyclooctatetraenyl anion

aromatic

planar

^1H NMR: $\delta 5.56$, singlet

Aromatic Dianions II

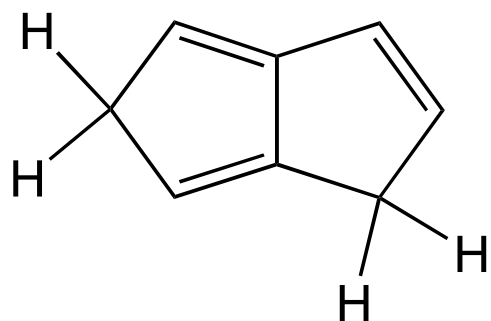

Dihydropentalene

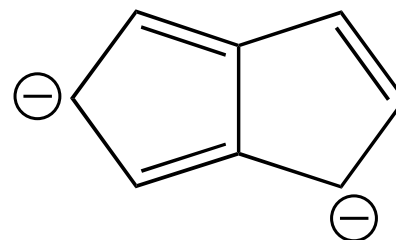

Pentalene dianion

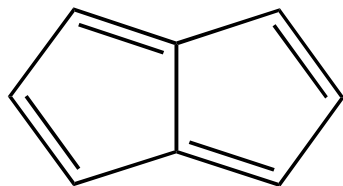

Pentalene

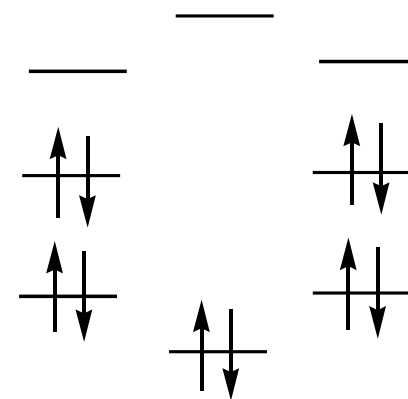
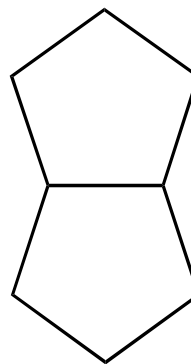

The End